

# FRONT & REAR AXLE

# SECTION AX

## CONTENTS

<b>FRONT AXLE</b> .....	2	DISASSEMBLY.....	11
Precautions .....	2	INSPECTION.....	12
PRECAUTIONS .....	2	ASSEMBLY .....	13
Preparation .....	2	Service Data and Specifications (SDS).....	15
SPECIAL SERVICE TOOLS .....	2	DRIVE SHAFT .....	15
COMMERCIAL SERVICE TOOLS.....	2	WHEEL BEARING (FRONT) .....	16
Noise, Vibration and Harshness (NVH)		<b>REAR AXLE</b> .....	17
Troubleshooting .....	3	Precautions .....	17
NVH TROUBLESHOOTING CHART .....	3	PRECAUTIONS .....	17
On-vehicle Service.....	3	Preparation .....	17
FRONT AXLE PARTS .....	3	SPECIAL SERVICE TOOLS .....	17
FRONT WHEEL BEARING .....	4	COMMERCIAL SERVICE TOOLS.....	17
DRIVE SHAFT .....	4	Noise, Vibration and Harshness (NVH)	
Wheel Hub and Knuckle.....	5	Troubleshooting .....	18
COMPONENTS .....	5	On-vehicle Service.....	18
REMOVAL.....	5	REAR AXLE PARTS.....	18
INSTALLATION.....	6	REAR WHEEL BEARING .....	18
DISASSEMBLY.....	7	Wheel Hub .....	19
INSPECTION.....	7	COMPONENTS .....	19
ASSEMBLY .....	8	REMOVAL.....	19
Drive Shaft .....	9	INSTALLATION.....	20
COMPONENTS .....	9	Service Data and Specifications (SDS).....	22
REMOVAL.....	9	WHEEL BEARING (REAR) .....	22
INSTALLATION.....	10		

GI  
MA  
EM  
LC  
EC  
FE  
CL  
MT  
AT  
**AX**  
SU  
BR  
ST  
RS  
BT  
HA  
SC  
EL  
IDX

# FRONT AXLE

## Precautions

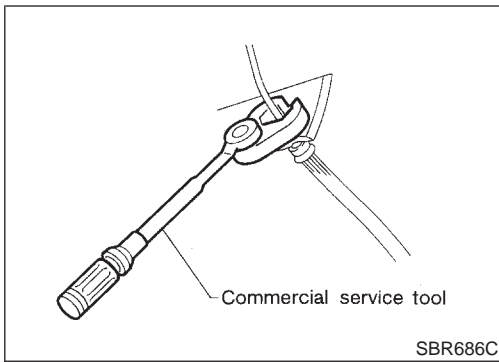

## Precautions

### PRECAUTIONS

NFAX0001

- When installing rubber parts, final tightening must be carried out under unladen condition\* with tires on ground.  
\*: Fuel, radiator coolant and engine oil full. Spare tire, jack, hand tools and mats in designated positions.
- After installing removed suspension parts, check wheel alignment and adjust if necessary.
- Use flare nut wrench when removing or installing brake tubes.
- Always torque brake lines when installing.

## Preparation

## SPECIAL SERVICE TOOLS

NFAX0002

The actual shapes of Kent-Moore tools may differ from those of special service tools illustrated here.

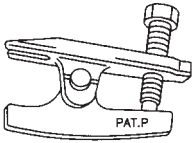
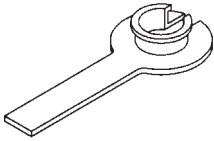
Tool number (Kent-Moore No.) Tool name	Description
HT72520000 (J25730-B) Ball joint remover	 <p>Removing tie-rod outer end and lower ball joint</p> <p>NT146</p>
KV38106700 (J34296) KV38106800 (J34297) Differential side oil seal protector	 <p>Installing drive shaft LH: KV38106700 (J34296) RH: KV38106800 (J34297)</p> <p>NT147</p>

## COMMERCIAL SERVICE TOOLS

NFAX0003

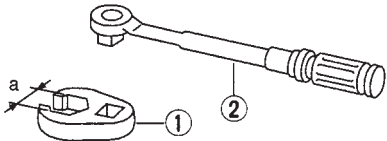
Tool name	Description
1 Flare nut crowfoot 2 Torque wrench	 <p>Removing and installing each brake piping a: 10 mm (0.39 in)</p> <p>NT360</p>

# FRONT AXLE

Noise, Vibration and Harshness (NVH) Troubleshooting

## Noise, Vibration and Harshness (NVH) Troubleshooting

=NFAX0004

### NVH TROUBLESHOOTING CHART

Use the chart below to help you find the cause of the symptom. If necessary, repair or replace these parts.

Reference page			—	AX-12	—	AX-5, 19	—	AX-4, 18	Refer to DRIVE SHAFT in this chart.	Refer to AXLE in this chart.	SU-4	SU-4	SU-4	BR-7	ST-5	
Possible cause and SUSPECTED PARTS			Excessive joint angle	Joint sliding resistance	Imbalance	Improper installation, looseness	Parts interference	Wheel bearing damage	DRIVE SHAFT	AXLE	SUSPENSION	TIRES	ROAD WHEEL	BRAKES	STEERING	
Symptom	DRIVE SHAFT	Noise, Vibration	×	×						×	×	×	×	×	×	
		Shake	×		×					×	×	×	×	×	×	
	AXLE	Noise				×	×		×		×	×	×	×	×	×
		Shake				×	×		×		×	×	×	×	×	×
		Vibration				×	×		×		×	×				×
		Shimmy				×	×					×	×	×	×	×
		Judder				×						×	×	×	×	×
Poor quality ride or handling				×	×	×				×	×	×				

×: Applicable

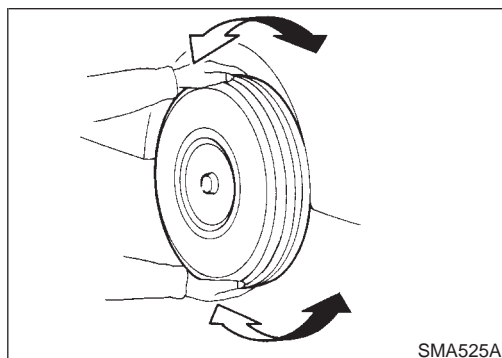

### On-vehicle Service

#### FRONT AXLE PARTS

NFAX0005

Check front axle and front suspension parts for excessive play, cracks, wear or other damage.

- Shake each front wheel to check for excessive play.
- Make sure that cotter pin is inserted.
- Retighten all axle and suspension nuts and bolts to the specified torque.

**Tightening torque:**

**Refer to SU-9, "FRONT SUSPENSION".**

## FRONT AXLE

On-vehicle Service (Cont'd)

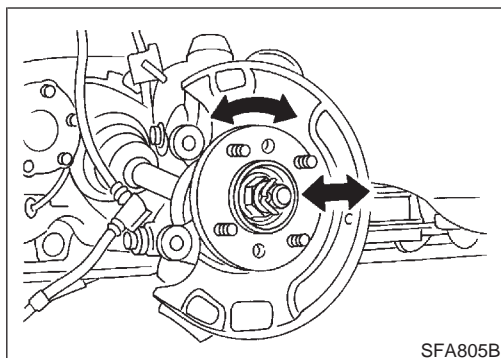

SFA805B

### FRONT WHEEL BEARING

NFAX0006

- Check that wheel bearings operate smoothly.
- Check axial end play.

**Axial end play:**

**0.05 mm (0.0020 in)**

If out of specification or wheel bearing does not turn smoothly, replace wheel bearing assembly.

Refer to "Wheel Hub and Knuckle", "FRONT AXLE", AX-5.

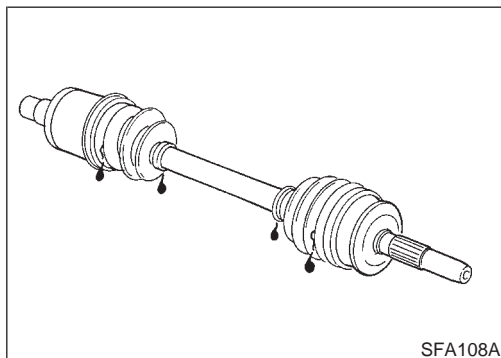

SFA108A

### DRIVE SHAFT

NFAX0007

Check for grease leakage or other damage.

## Wheel Hub and Knuckle COMPONENTS

=NFAX0008

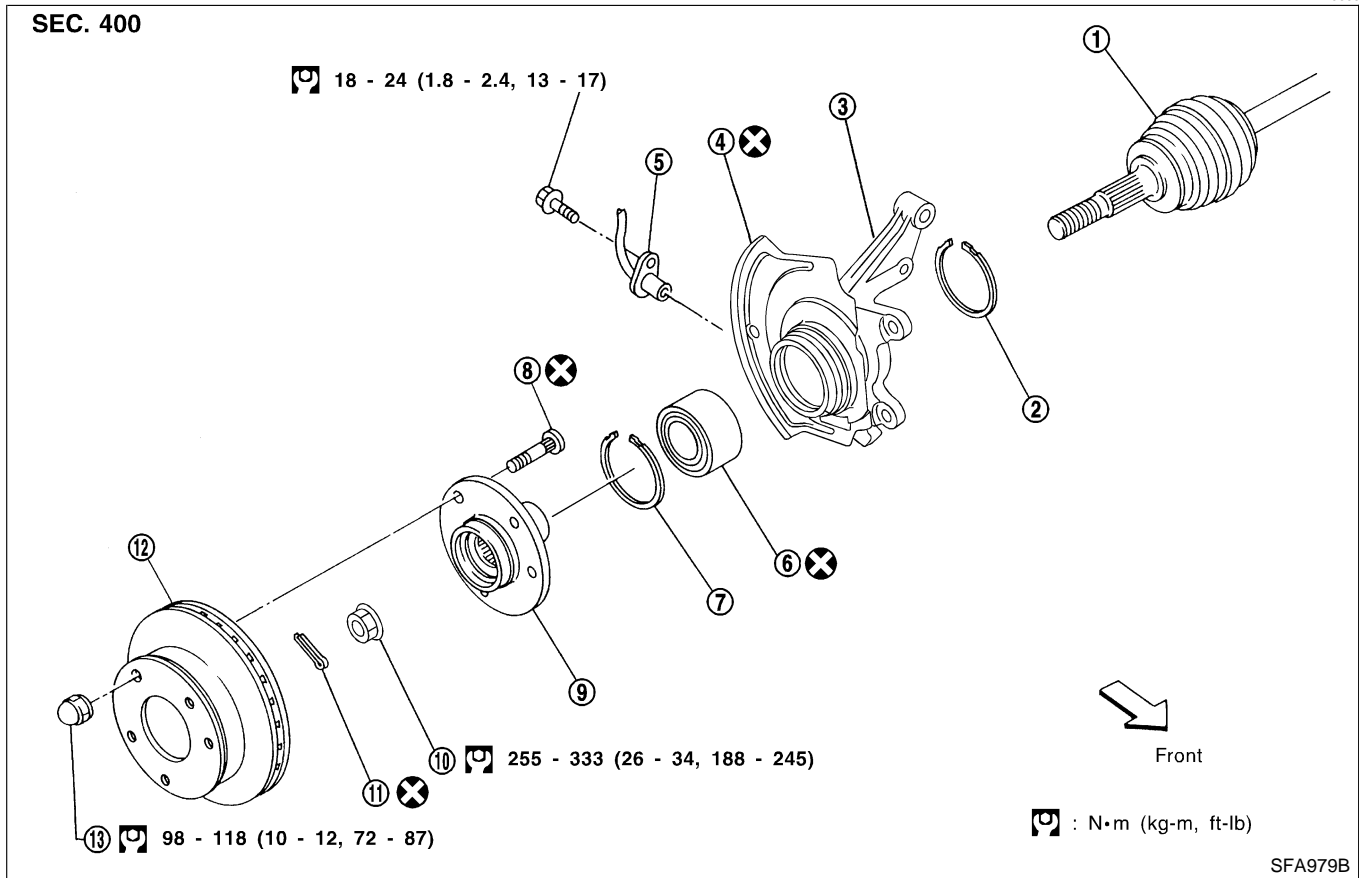

- |                 |                           |                            |
|-----------------|---------------------------|----------------------------|
| 1. Drive shaft  | 6. Wheel bearing assembly | 10. Wheel bearing lock nut |
| 2. Snap ring    | 7. Snap ring              | 11. Cotter pin             |
| 3. Knuckle      | 8. Hub bolt               | 12. Brake disc             |
| 4. Baffle plate | 9. Wheel hub              | 13. Wheel nut              |
| 5. ABS sensor   |                           |                            |

### REMOVAL

NFAX0009

#### CAUTION:

Before removing the front axle assembly, disconnect the ABS wheel sensor from the assembly. Then move it away from the front axle assembly area.

Failure to do so may result in damage to the sensor wires and the sensor becoming inoperative.

1. Remove wheel bearing lock nut.

2. Remove brake caliper assembly and rotor.

Brake hose need not be disconnected from brake caliper. In this case, suspend caliper assembly with wire so as not to stretch brake hose. Be careful not to depress brake pedal, or piston will pop out.

Make sure brake hose is not twisted.

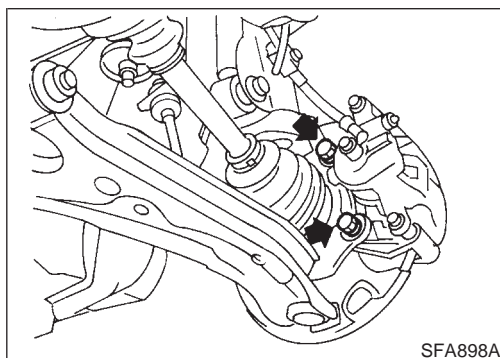

SFA898A

# FRONT AXLE

## Wheel Hub and Knuckle (Cont'd)

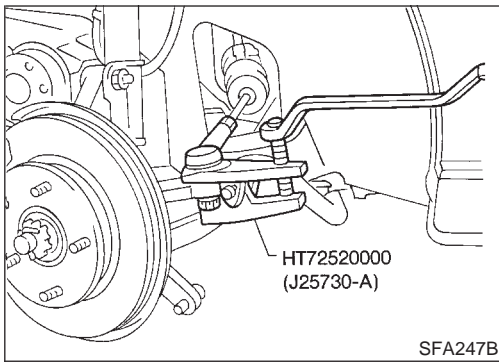

3. Separate tie-rod from knuckle with Tool.  
**Install stud nut on stud bolt to prevent damage to stud bolt.**

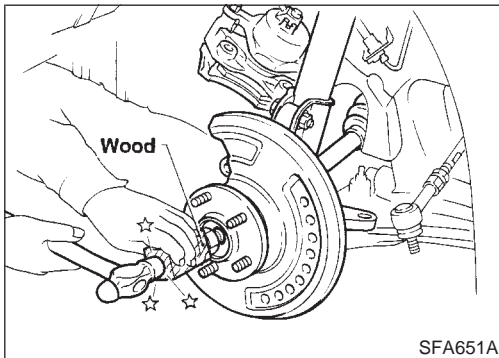

4. Separate drive shaft from knuckle by lightly tapping it. If it is hard to remove, use a puller.  
**Cover boots with shop towel so as not to damage them when removing drive shaft.**

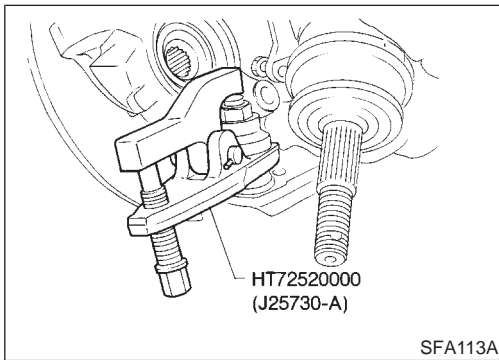

5. Loosen lower ball joint tightening nut.
6. Separate knuckle from lower ball joint stud with Tool.
7. Remove knuckle from transverse link.

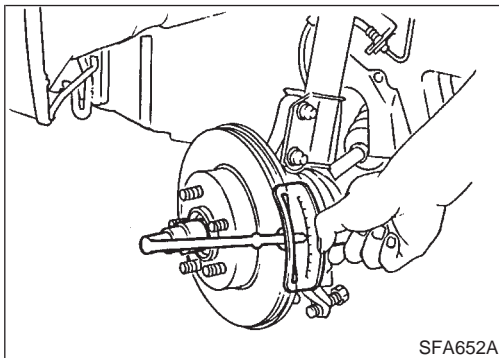

## INSTALLATION

NFAX0010

1. Install knuckle with wheel hub.  
**When installing knuckle to strut, be sure to hold bolts and tighten nuts.**

 : 176 - 189 N·m (17.9 - 19.3 kg·m, 130 - 139 ft·lb)

**Before tightening, apply oil to threaded portion of drive shaft.**

2. Tighten wheel bearing lock nut.  
 : 255 - 333 N·m (26 - 34 kg·m, 188 - 245 ft·lb)
3. Check that wheel bearings operate smoothly.

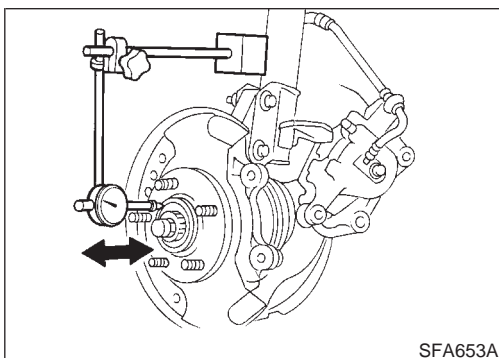

4. Check wheel bearing axial end play.  
**Axial end play:**  
**0.05 mm (0.0020 in)**

# FRONT AXLE

Wheel Hub and Knuckle (Cont'd)

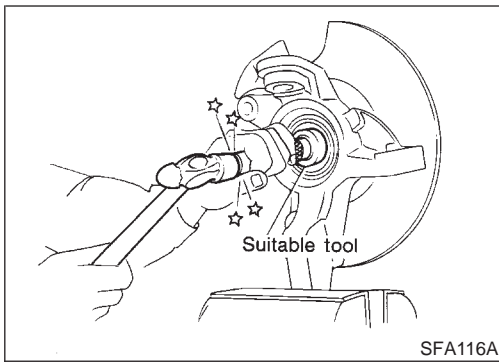

SFA116A

## DISASSEMBLY

### CAUTION:

When removing wheel hub or wheel bearing from knuckle, replace wheel bearing assembly (outer race, inner races and grease seals) with a new one.

### Wheel Hub

Drive out hub with inner race (outside) from knuckle with a suitable tool.

NFAX0011

GI

MA

EM

LC

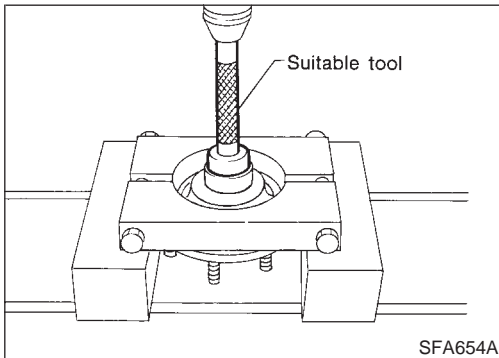

SFA654A

### Wheel Bearing

When replacing wheel bearing, replace complete wheel bearing assembly (Inner races and outer race).

1. Remove bearing inner race (outside).

NFAX0011S02

EC

FE

CL

MT

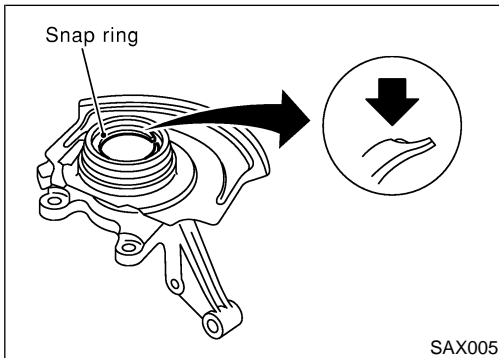

SAX005

2. Remove snap rings.

AT

AX

SU

BR

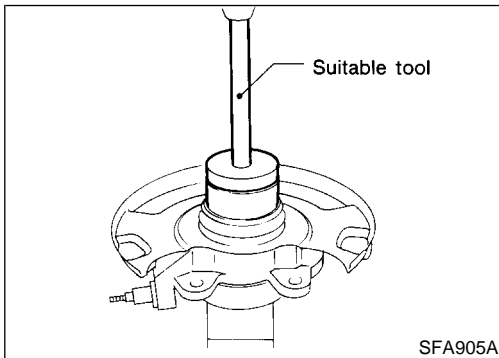

SFA905A

3. Press out bearing outer race.

ST

RS

BT

HA

## INSPECTION

### Wheel Hub and Knuckle

Check wheel hub and knuckle for cracks by using a magnetic exploration or dyeing test.

NFAX0012

SC

NFAX0012S01

EL

### Snap Ring

Check snap ring for wear or cracks. Replace if necessary.

NFAX0012S02

IDX

# FRONT AXLE

## Wheel Hub and Knuckle (Cont'd)

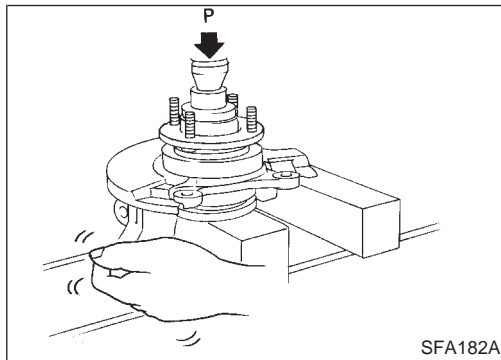
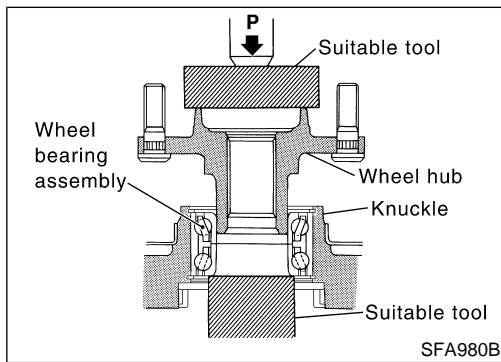
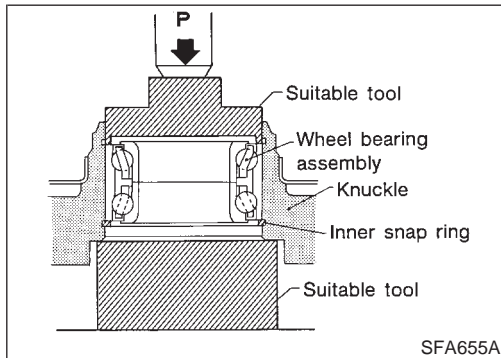
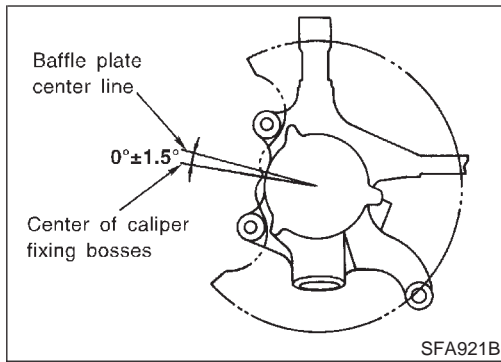

## ASSEMBLY

NFAX0013

- When removing baffle plate, replace it with a new one.
- When installing the baffle plate, press new plate so that it is in contact with knuckle wall. Refer to figure at left.

1. Install inner snap ring into groove of knuckle.
2. Press new wheel bearing assembly into knuckle until it contacts snap ring.

**Maximum load P:**

**29 kN (3 ton, 3.3 US ton, 3.0 Imp ton)**

### CAUTION:

- Do not press inner race of wheel bearing assembly.
  - Do not apply oil or grease to mating surfaces of wheel bearing outer race and knuckle.
3. Install outer snap ring into groove of knuckle.

4. Press wheel hub into knuckle until it stops when the end of the wheel bearing is hit.

**Maximum load P:**

**49 kN (5 ton, 5.5 US ton, 4.9 Imp ton)**

5. Check bearing operation.
  - a. Add load P with press.

**Load P:**

**49.0 kN**

**(5.0 ton, 5.5 US ton, 4.92 Imp ton)**

- b. Spin knuckle several turns in both directions.
- c. Make sure that wheel bearings operate smoothly.



## Drive Shaft COMPONENTS

NFAX0016

GI  
MA  
EM  
LC  
EC  
FE  
CL  
MT  
AT  
**AX**  
SU  
BR  
ST  
RS  
BT  
HA  
SC  
EL  
IDX

### SEC. 391

#### Circular clip:

Circular clips should be properly meshed with differential side gear (transaxle side) and with joint assembly (wheel side). Make sure they will not come out.

**Be careful not to damage boots. Use suitable protector or cloth during removal and installation.**

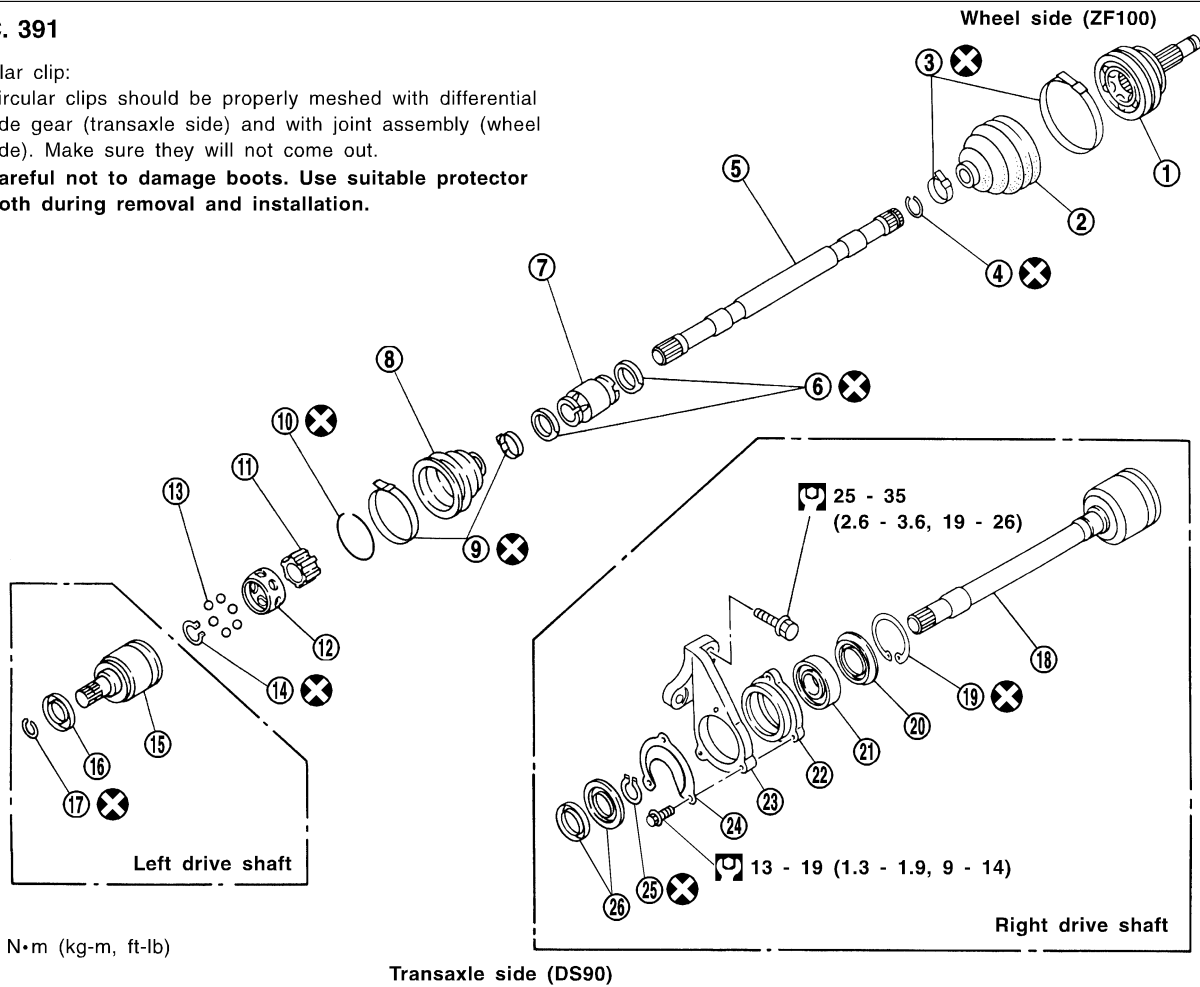

SAX016

- |                        |  |                              |
|------------------------|--|------------------------------|
| 1. Joint assembly      | 10. Snap ring                                | 19. Snap ring                |
| 2. Boot                | 11. Inner race                               | 20. Dust shield              |
| 3. Boot band           | 12. Cage                                     | 21. Support bearing          |
| 4. Circular clip       | 13. Ball                                     | 22. Support bearing retainer |
| 5. Drive shaft         | 14. Snap ring                                | 23. Bracket                  |
| 6. Dynamic damper band | 15. Slide joint housing                      | 24. Snap ring                |
| 7. Dynamic damper      | 16. Dust shield                              | 25. Dust shield              |
| 8. Boot                | 17. Circular clip                            |                              |
| 9. Boot band           | 18. Slide joint housing with extension shaft |                              |

### REMOVAL

NFAX0014

1. Remove wheel bearing lock nut.  
**Brake caliper need not be disconnected. Do not twist or stretch brake hose when moving components.**
2. Remove strut lower mount bolts.
3. Remove brake hose clip.

# FRONT AXLE

## Drive Shaft (Cont'd)

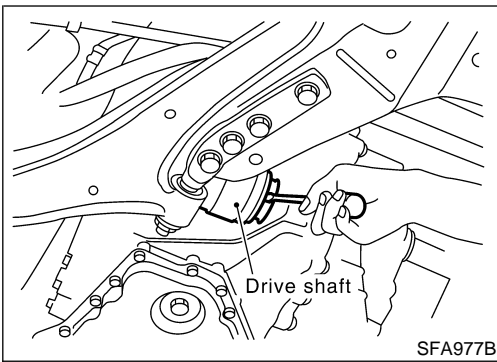

4. Separate drive shaft from knuckle by lightly tapping it. If it is hard to remove, use a puller.  
**Cover boots with shop towel so as not to damage them when removing drive shaft.**  
Refer to "Wheel Hub and Knuckle", "FRONT AXLE", AX-5.
5. Remove right drive shaft from transaxle.

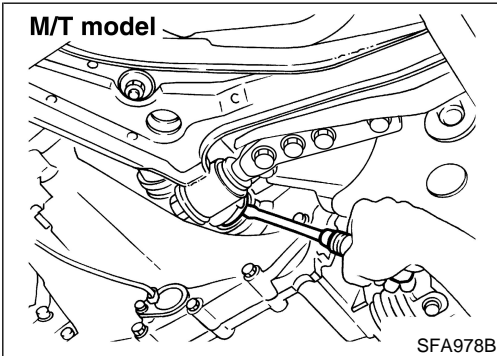

6. Remove left drive shaft from transaxle.  
— **For M/T models** —
  - Pry off drive shaft from transaxle as shown at left.

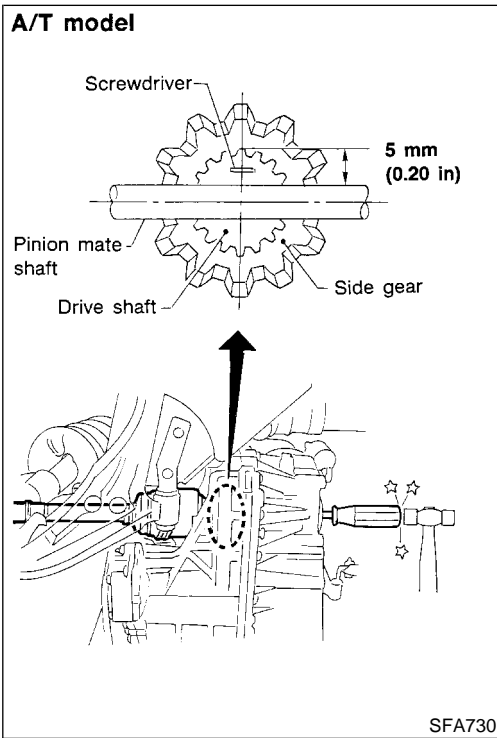

- **For A/T models** —
- Insert screwdriver into transaxle opening for right drive shaft and strike with a hammer.  
**Be careful not to damage pinion mate shaft and side gear.**

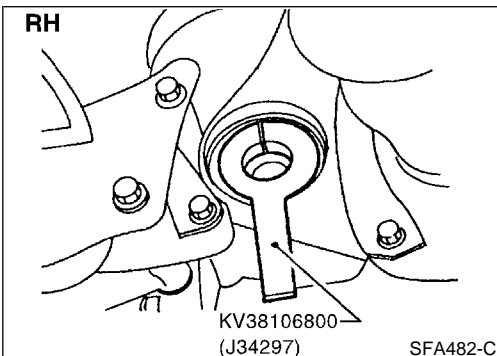

## INSTALLATION

### Transaxle Side

1. Drive a new oil seal to transaxle. Refer to MT-8 or AT-282, "Replacing Oil Seal" or "Differential Side Oil Seal Replacement", "ON-VEHICLE SERVICE".
2. Set Tool along the inner circumference of oil seal.

NFAX0015

NFAX0015S01

# FRONT AXLE

Drive Shaft (Cont'd)

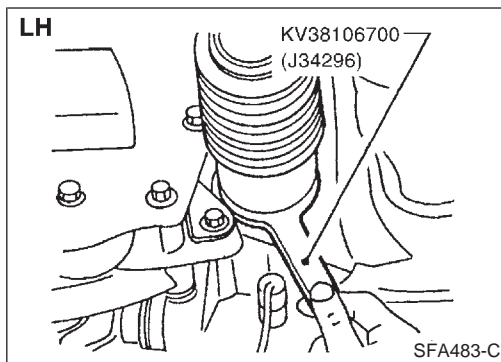

3. Insert drive shaft into transaxle. Be sure to properly align the serrations and then withdraw Tool.
4. Push drive shaft, then press-fit circular clip on the drive shaft into circular clip groove of side gear.
5. After its insertion, try to pull the flange out of the slide joint by hand. If it pulls out, the circular clip is not properly meshed with the side gear.

GI

MA

EM

LC

## Wheel Side

NFAX0015S02

- Install drive shaft into knuckle.
- Tighten upper knuckle nut and wheel bearing lock nut. Refer to section Installation in "Wheel Hub and Knuckle", "FRONT AXLE", AX-5.

EC

FE

CL

MT

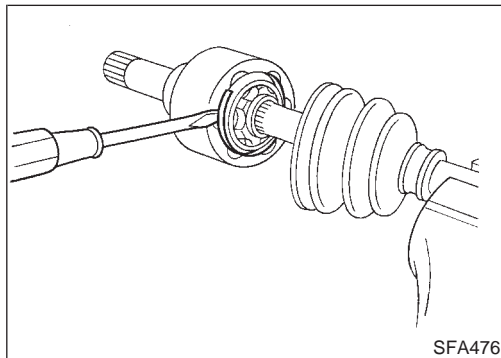

## DISASSEMBLY

NFAX0017

### Transaxle Side

NFAX0017S01

1. Remove boot bands.
2. Put matching marks on slide joint housing and inner race, before separating joint assembly.
3. Remove stopper ring with a screwdriver, and pull out slide joint housing.

AT

AX

SU

BR

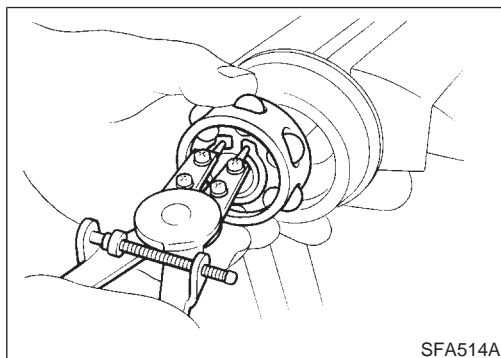

4. Put matching marks on inner race and drive shaft.
5. Remove snap ring, then remove ball cage, inner race and balls as a unit.
6. Draw out boot.

ST

RS

**Cover drive shaft serrations with tape so as not to damage the boot.**

BT

HA

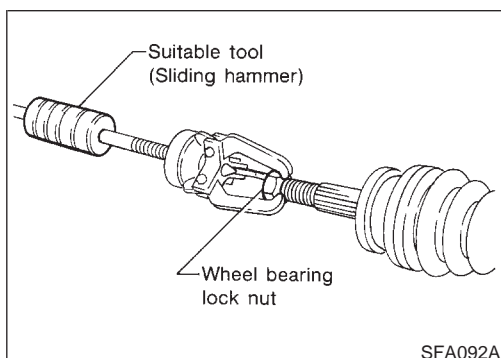

## Wheel Side

NFAX0017S02

### CAUTION:

**The joint on the wheel side cannot be disassembled.**

1. Before separating joint assembly, put matching marks on drive shaft and joint assembly.
2. Separate joint assembly with a suitable tool.

SC

EL

**Be careful not to damage threads on drive shaft.**

3. Remove boot bands.
4. Draw out boot.

IDX

# FRONT AXLE

## Drive Shaft (Cont'd)

NFAX0017S03

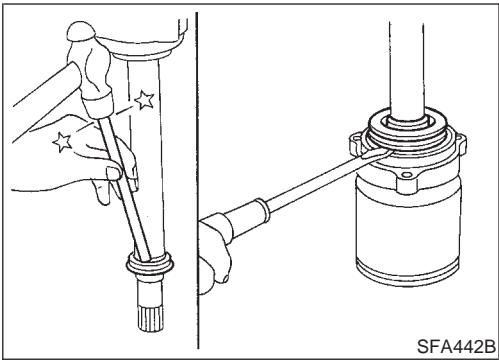

### Support Bearing

1. Remove dust shield.

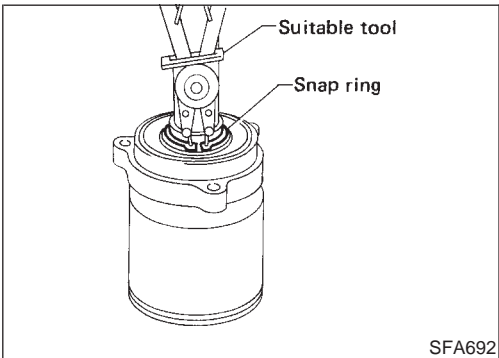

2. Remove snap ring.

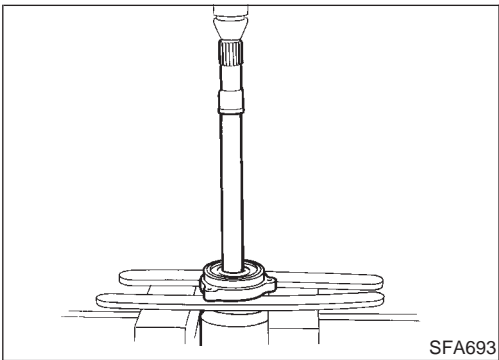

3. Press support bearing assembly off of drive shaft.

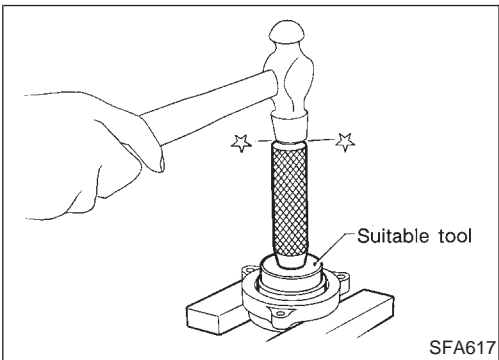

4. Separate support bearing from retainer.

### INSPECTION

Thoroughly clean all parts in cleaning solvent, and dry with compressed air. Check parts for evidence of deformation or other damage.

NFAX0018

### Drive Shaft

Replace drive shaft if it is twisted or cracked.

NFAX0018S01

### Boot

Check boot for fatigue, cracks or wear. Replace boot with new boot bands.

NFAX0018S02

## Joint Assembly (Transaxle side)

NFAX0018S03

- Check serration for deformation. Replace if necessary.
- Check slide joint housing for any damage. Replace if necessary.

GI

## Joint Assembly (Wheel side)

NFAX0018S04

Replace joint assembly if it is deformed or damaged.

MA

## Support Bearing

NFAX0018S05

Make sure wheel bearing rolls freely and is free from noise, cracks, pitting or wear.

EM

## Support Bearing Bracket

NFAX0018S06

Check support bearing bracket for cracks with a magnetic exploration or dyeing test.

LC

EC

## ASSEMBLY

NFAX0019

- After drive shaft has been assembled, ensure that it moves smoothly over its entire range without binding.
- Use NISSAN GENUINE GREASE or equivalent after every overhaul.

FE

CL

MT

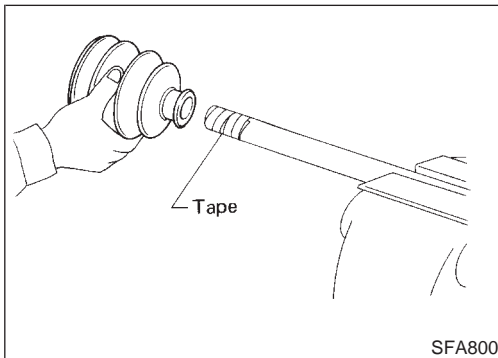

SFA800

## Wheel Side

NFAX0019S01

1. Install boot and new small boot band on drive shaft.

AT

**Cover drive shaft serration with tape so as not to damage boot during installation.**

AX

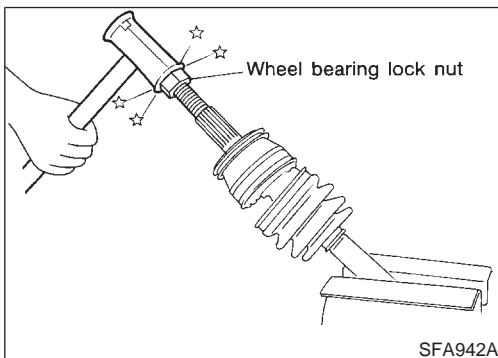

SFA942A

2. Set joint assembly onto drive shaft by lightly tapping it. Install joint assembly securely, ensuring marks which were made during disassembly are properly aligned.

ST

RS

BT

HA

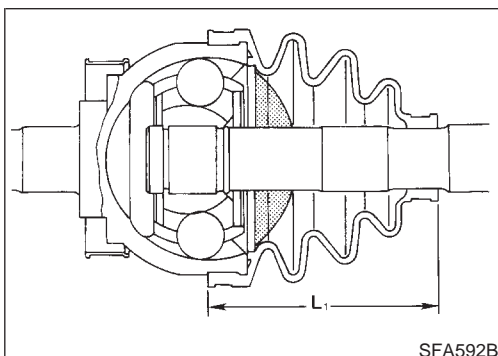

SFA592B

3. Pack drive shaft with specified amount of grease.

**Specified amount of grease:**

**135 - 145 g (4.76 - 5.11 oz)**

SC

4. Make sure that boot is properly installed on the drive shaft groove. Set boot so that it does not swell and deform when its length is "L<sub>1</sub>".

EL

IDX

**Length "L<sub>1</sub>":**

**103 mm (4.06 in)**

# FRONT AXLE

## Drive Shaft (Cont'd)

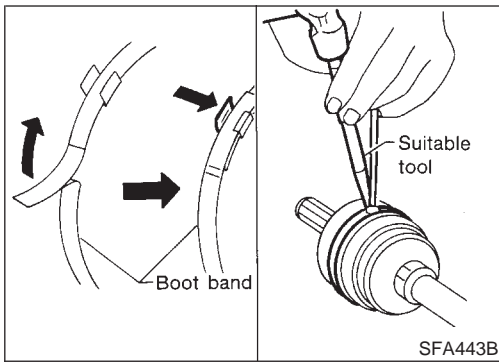

5. Lock new larger and smaller boot bands securely with a suitable tool.

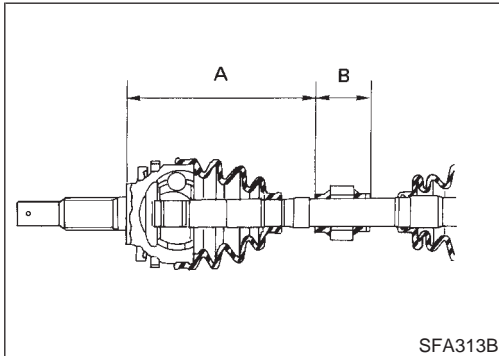

### Dynamic Damper

NFAX0019S02

1. Use new damper bands when installing.
2. Install dynamic damper from stationary-joint side while holding it securely.

#### Length:

**"A": 205 - 215 mm (8.07 - 8.46 in)**

**"B": 50 mm (1.97 in) (Except M/T model with LSD)  
70 mm (2.76 in) (M/T model with LSD)**

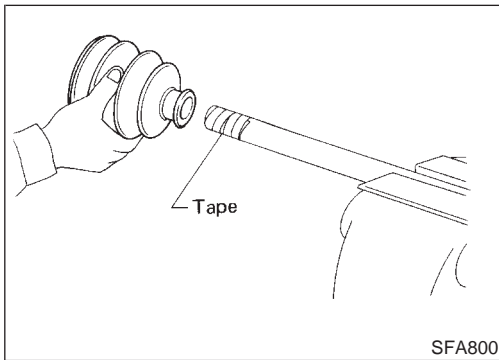

### Transaxle Side

NFAX0019S03

1. Install boot and new small boot band on drive shaft.

**Cover drive shaft serration with tape so as not to damage boot during installation.**

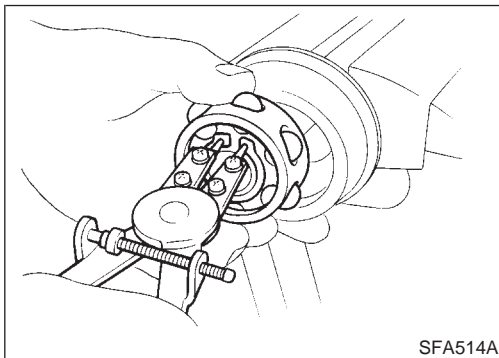

2. Install ball cage, inner race and balls as a unit, making sure the marks which were made during disassembly are properly aligned.
3. Install new snap ring.

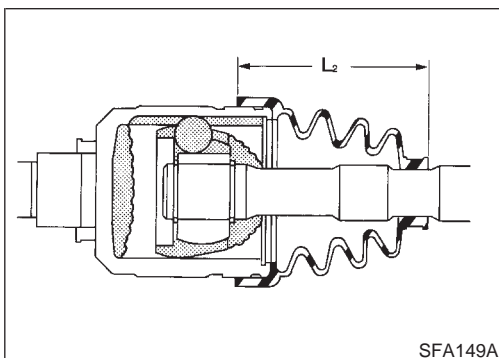

4. Pack drive shaft with specified amount of grease.

**Specified amount of grease:  
165 - 175 g (5.82 - 6.17 oz)**

5. Install slide joint housing, then install new snap ring.
6. Make sure that boot is properly installed on the drive shaft groove.  
Set boot so that it does not swell and deform when its length is "L<sub>2</sub>".

**Length "L<sub>2</sub>":**

**98 mm (3.86 in)**

# FRONT AXLE

Drive Shaft (Cont'd)

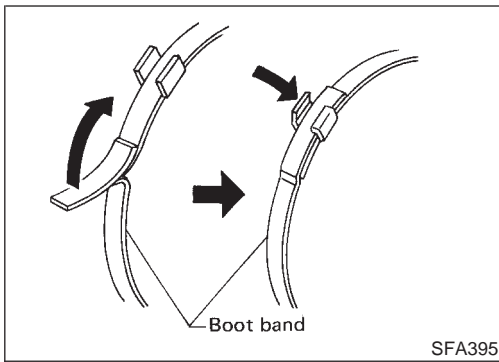

- Lock new larger and smaller boot bands securely with a suitable tool.

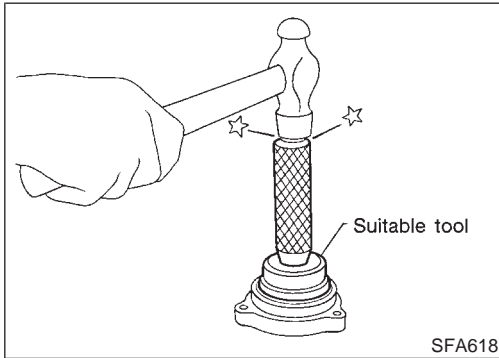

## Support Bearing

NFAX0019S04

- Press bearing into retainer.

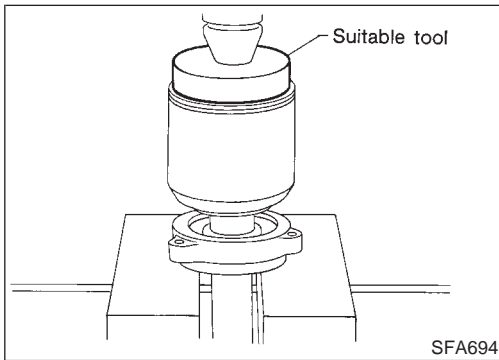

- Press drive shaft into bearing.

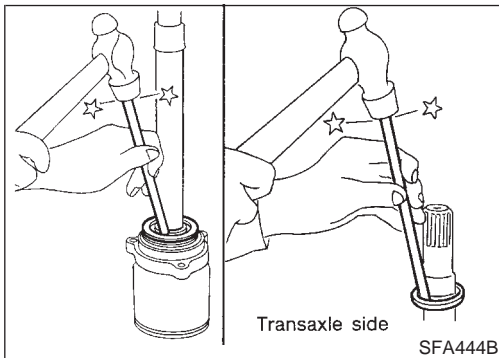

- Install snap ring.
- Install new dust shield.

## Service Data and Specifications (SDS) DRIVE SHAFT

NFAX0020

Applied model			All
Joint type	Transaxle side	DS90	
	Wheel side	ZF100	
Grease	Quality	Nissan genuine grease or equivalent	
	Capacity g (oz)	Transaxle side	165 - 175 (5.82 - 6.17)
		Wheel side	135 - 145 (4.76 - 5.11)

GI  
MA  
EM  
LC  
EC  
FE  
CL  
MT  
AT  
**AX**  
SU  
BR  
ST  
RS  
BT  
HA  
SC  
EL

IDX

# FRONT AXLE

## Service Data and Specifications (SDS) (Cont'd)

Applied model		All
Boot length mm (in)	Transaxle side "L <sub>2</sub> "	98 (3.86)
	Wheel side "L <sub>1</sub> "	103 (4.06)

Transaxle side

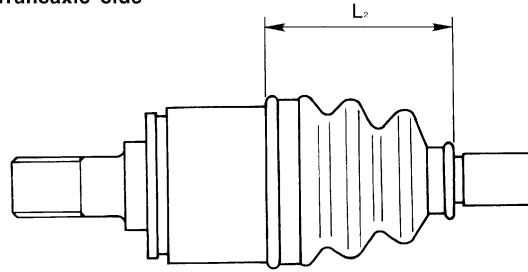

SFA961AA

Wheel side

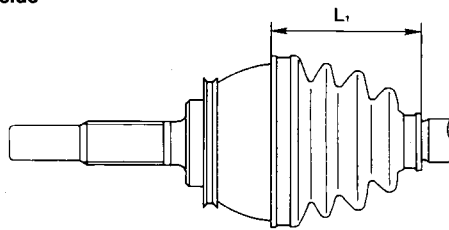

SFA962A

## WHEEL BEARING (FRONT)

NFAX0021

Wheel bearing axial end play limit mm (in)	0.05 (0.0020)
Wheel bearing lock nut tightening torque N-m (kg-m, ft-lb)	255 - 333 (26 - 34, 188 - 245)



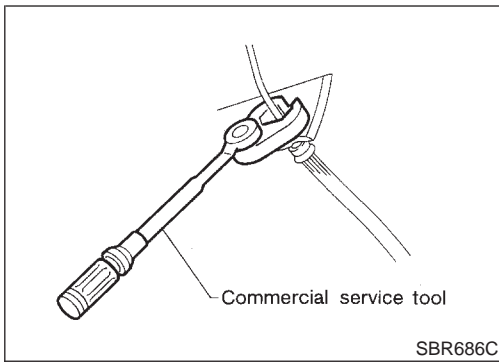

## Precautions

### PRECAUTIONS

- When installing each rubber part, final tightening must be carried out under unladen condition\* with tires on ground. \*: Fuel, radiator coolant and engine oil full. Spare tire, jack, hand tools and mats in designated positions.
- Use flare nut wrench when removing or installing brake tubes.
- After installing removed suspension parts, check wheel alignment.
- Do not jack up at the trailing arm and lateral link.
- Always torque brake lines when installing.

NFAX0022

GI

MA

EM

LC

EC

FE

CL

MT

## Preparation

### SPECIAL SERVICE TOOLS

The actual shapes of Kent-Moore tools may differ from those of special service tools illustrated here.

NFAX0032

Tool number (Kent-Moore No.) Tool name	Description
ST15310000 ( — ) Drift	<p>Install ABS sensor rotor                      a: 84 mm (3.31 in) dia.                      b: 96 mm (3.78 in) dia.                      c: 8 mm (0.31 in)                      d: 20 mm (0.79 in)</p> <p>NT607</p>

AX

SU

BR

ST

### COMMERCIAL SERVICE TOOLS

NFAX0024

Tool name	Description
GG94310000 1 Flare nut crowfoot 2 Torque wrench	<p>Removing and installing brake piping                      a: 10 mm (0.39 in)</p> <p>NT360</p>
Drift	<p>Install ABS sensor rotor                      a: 75 mm (2.95 in) dia.                      b: 62 mm (2.44 in) dia.</p> <p>NT371</p>

RS

BT

HA

SC

EL

IDX

## REAR AXLE

Noise, Vibration and Harshness (NVH) Troubleshooting

### Noise, Vibration and Harshness (NVH) Troubleshooting

Refer to "Noise, Vibration and Harshness (NVH) Troubleshooting", "FRONT AXLE", AX-3.

NFAX0025

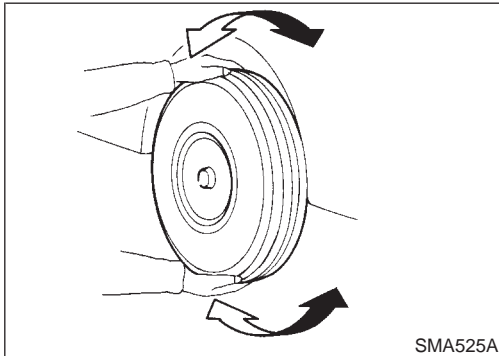

SMA525A

### On-vehicle Service

#### REAR AXLE PARTS

Check axle and suspension parts for excessive play, wear or damage.

NFAX0026

- Shake each rear wheel to check for excessive play.

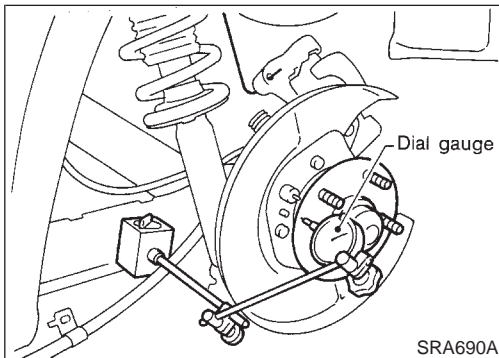

SRA690A

#### REAR WHEEL BEARING

NFAX0027

- Check axial end play.  
**Axial end play:**  
**0.05 mm (0.0020 in)**
- Check that wheel hub bearings operate smoothly.
- Check tightening torque of wheel bearing lock nut.  
**⚙️ : 187 - 254 N·m (19 - 26 kg-m, 138 - 188 ft-lb)**
- Replace wheel bearing assembly if there is axial end play or wheel bearing does not turn smoothly. Refer to "Wheel Hub", "REAR AXLE", AX-19.

Wheel Hub  
COMPONENTS

NFAX0028

GI  
MA  
EM  
LC  
EC  
FE  
CL  
MT  
AT  
AX  
SU  
BR  
ST  
RS  
BT  
HA  
SC  
EL  
IDX

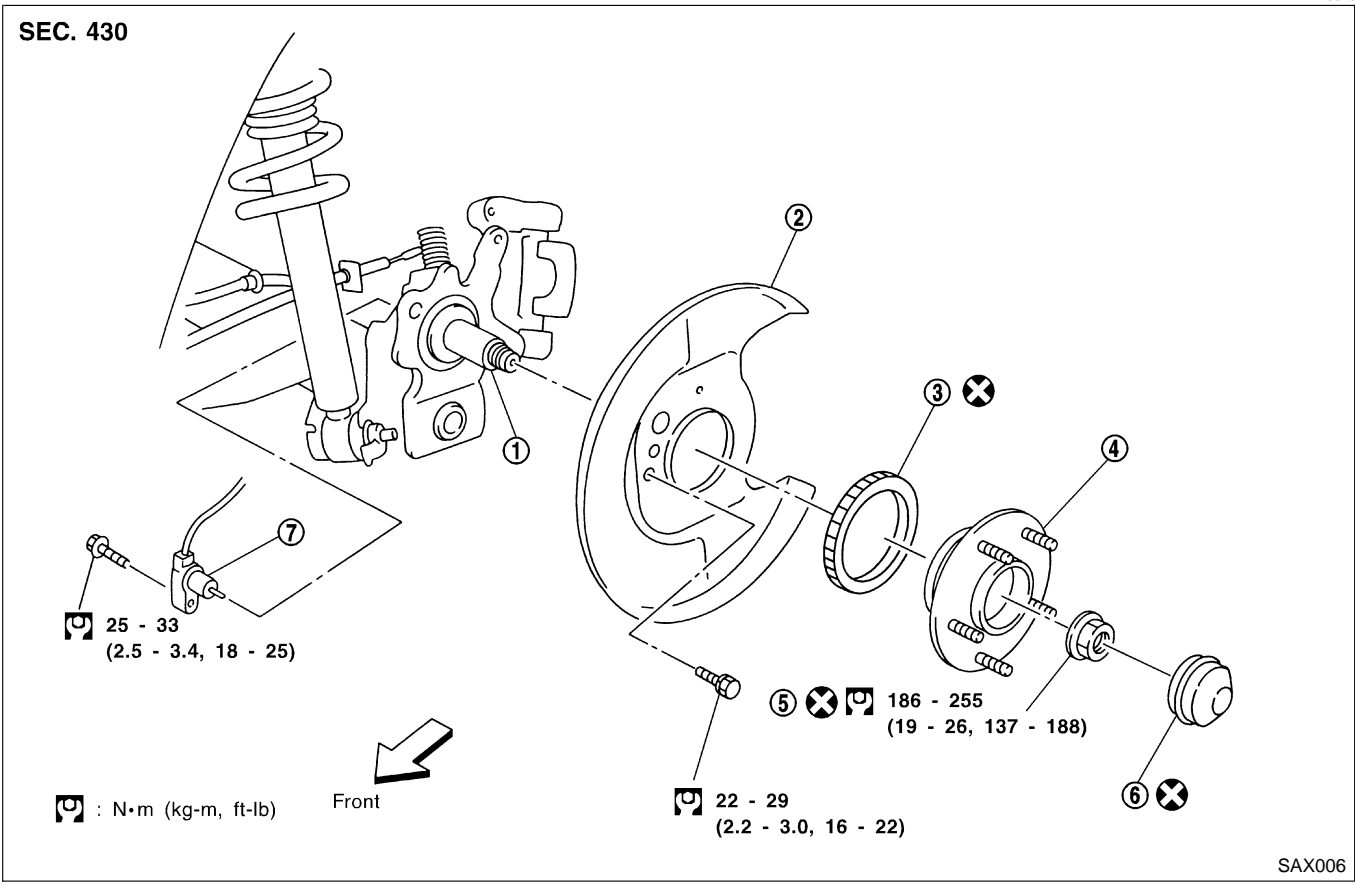

- |                     |                           |               |
|---------------------|---------------------------|---------------|
| 1. Spindle          | 4. Wheel hub bearing      | 6. Hub cap    |
| 2. Baffle plate     | 5. Wheel bearing lock nut | 7. ABS sensor |
| 3. ABS sensor rotor |                           |               |

REMOVAL

NFAX0029

**CAUTION:**

- Before removing the rear wheel hub assembly, disconnect the ABS wheel sensor from the assembly. Then move it away from the hub assembly. Failure to do so may result in damage to the sensor wires and the sensor becoming inoperative.
- Wheel hub bearing does not require maintenance. If any of the following symptoms are noted, replace wheel hub bearing assembly.
  - 1) Growling noise is emitted from wheel hub bearing during operation.
  - 2) Wheel hub bearing drags or turns roughly. This occurs when turning hub by hand after bearing lock nut is tightened to specified torque.

## REAR AXLE

### Wheel Hub (Cont'd)

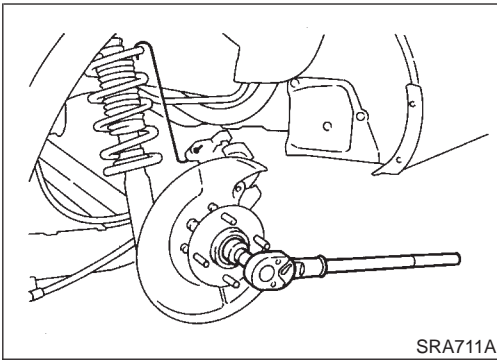

1. Remove brake caliper assembly.
2. Remove wheel bearing lock nut.
3. Remove brake rotor.
4. Remove wheel hub bearing from spindle.

**Brake hose does not need to be disconnected from brake caliper.**

**Suspend caliper assembly with wire so as not to stretch brake hose.**

**Be careful not to depress brake pedal, or piston will pop out. Make sure brake hose is not twisted.**

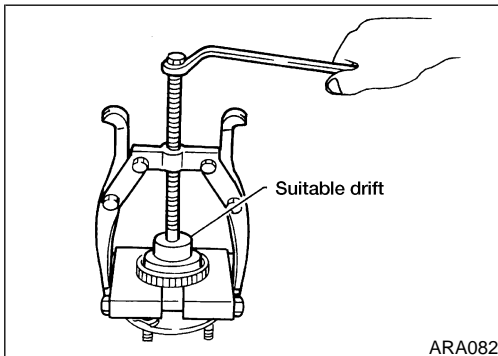

5. Remove the sensor rotor using suitable puller, drift and bearing replacer.

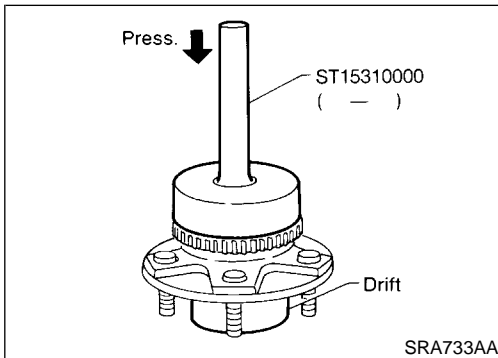

### INSTALLATION

NFAX0030

- With vehicles equipped with ABS, press-fit ABS sensor rotor into wheel hub bearing using a drift.

**Do not reuse ABS sensor rotor. When installing, replace it with a new one.**

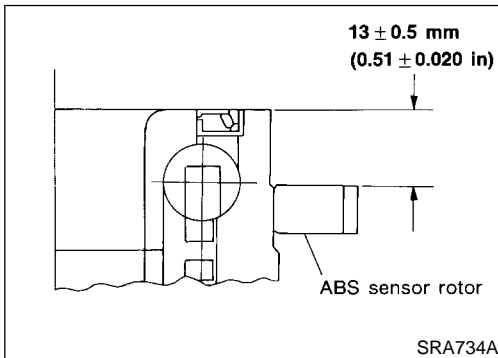

- Press-fit ABS sensor rotor as far as the location shown in figure at left.

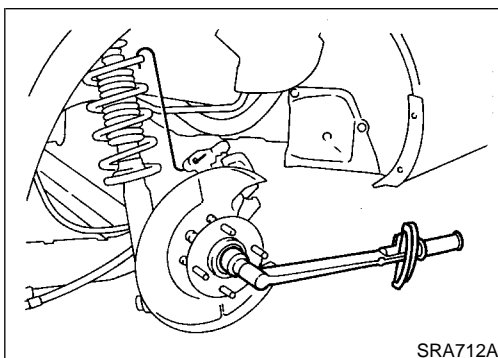

- Install wheel hub bearing.
- Tighten wheel bearing lock nut.  
Before tightening, apply oil to threaded portion of rear spindle.  
**Do not reuse wheel bearing lock nut.**  
**⚙️ : 187 - 254 N-m (19 - 26 kg-m, 138 - 188 ft-lb)**
- Check that wheel bearings operate smoothly.

# REAR AXLE

Wheel Hub (Cont'd)

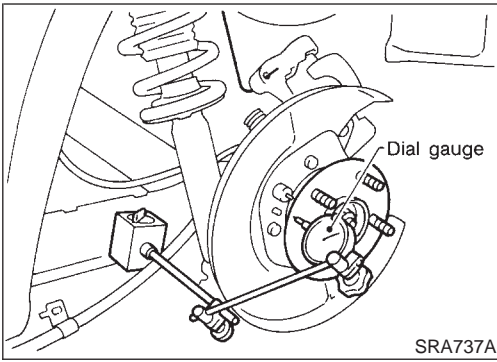

- Check wheel hub bearing axial end play.

**Axial end play:**  
**0.05 mm (0.0020 in)**

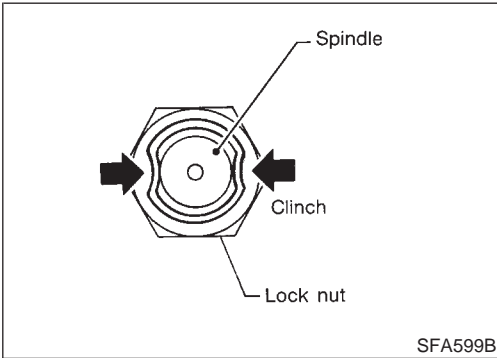

- Clinch two places of lock nut.

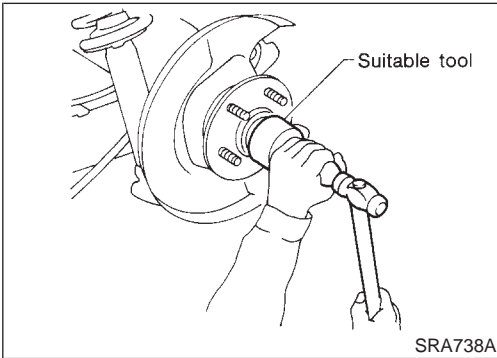

- Install hub cap using a suitable tool.  
**Do not reuse hub cap. When installing, replace it with a new one.**

GI

MA

EM

LC

EC

FE

CL

MT

AT

**AX**

SU

BR

ST

RS

BT

HA

SC

EL

IDX

# REAR AXLE

*Service Data and Specifications (SDS)*

## Service Data and Specifications (SDS) WHEEL BEARING (REAR)

=NFAX0031

Wheel bearing axial end play mm (in)	0.05 (0.0020)
Wheel bearing lock nut tightening torque N-m (kg-m, ft-lb)	187 - 254 (19 - 26, 138 - 188)